



ISSN Online: 2709-9180
ISSN Print: 2709-9172

INTERNATIONAL BULLETIN
OF LITERATURE AND LINGUISTICS

Vol. 6 No. 2 (June) 2023

Pages: 23-50

Published by: Research Syndicate

Email: researchsyndicate.vv@gmail.com Website: <http://www.researchsyndicate.com.pk>

**NOUN PHRASE STRUCTURE RULES AS A COMPARATIVE STUDY OF
ENGLISH AND URDU LANGUAGE: THE CASE OF ARTICLES**

**Khurram Shahzad, (M.Phil Scholar), Minhaj University Lahore.
Syeda Sadaf Fatima, (M.Phil Scholar), Minhaj University Lahore.
Zafar Iqbal, (M.Phil Scholar) Minhaj University Lahore**

ABSTRACT

In this paper, we intend to analyse the sentence structures of English and Urdu, the most commonly used languages in Pakistan. In etymology, punctuation is the arrangement of basic standards that administer the organisation of provisions, expressions, and words in a language. English syntax is the assortment of rules that portray the structure of sentences in the English language. This incorporates the structure of words, expressions, provisos, and sentences. Then again, Urdu, the most widely used language of Pakistan, has its own sentence structure, which is to some degree like the syntax of English, yet it varies from English punctuation in different ways. For instance, Urdu has linguistic gender orientation: all Urdu things are manly or ladylike. Some Urdu descriptive words change as per the sexual orientation of the thing they describe, while others don't. There are no positive articles in the Urdu language. Like English, Urdu has transitive action words (which require an immediate item) and intransitive action words (which don't take objects); however, the distinction plays a considerably more significant role in Urdu. Two parts of the word request are distinctive in Urdu and English. Right off the bat, the standard word order in Urdu is Subject-Object-Verb, as opposed to Subject-Verb-Object in English. It's additionally fascinating to note that Urdu utilises post-positions (which come after things), as opposed to relational words (which precede things). In this unique situation, Urdu local speakers have issues with the correct use of relational words.

Key words: Anglo-Norman, Article-less language, English language, Urdu, inflectional system,

Introduction

The historical backdrop of English is ordinarily, if maybe too flawlessly, isolated into three periods for the most part called Old English (or Anglo-Saxon), Middle English, and Modern English. The most punctual period starts with the movement of certain Germanic clans from the landmass to Britain in the fifth century A.D., however no records of their language make due from before the seventh century, and it proceeds until the finish of the eleventh century or somewhat later. At that point Latin, Old Norse (the language of the Viking trespassers), and particularly the Anglo-Norman French of the prevailing class after the Norman Conquest in 1066



ISSN Online: 2709-9180
ISSN Print: 2709-9172

**INTERNATIONAL BULLETIN
OF LITERATURE AND LINGUISTICS**

Vol. 6 No. 2 (June) 2023

Pages: 23-50

Published by: Research Syndicate

Email: researchsyndicate.vv@gmail.com Website: <http://www.researchsyndicate.com.pk>

had started to substantially affect the dictionary, and the all around created inflectional framework that exemplifies the sentence structure of Old English had started to separate.

Urdu then again, is a dominant language of South Asia, which has been picking up in notoriety since the coming of freedom of India and Pakistan. It is one of the eighteen national dialects recorded in the Constitution of India, just as the national language of Pakistan. Urdu is a South Asian language in the Indo-Aryan branch in the Indo-European group of dialects. Truly, Urdu had been created from the sub-provincial language of the Delhi region, which turns into an abstract language in the eighteenth century. Two very comparative standard types of the language created in Delhi, and in Lucknow in present day Uttar Pradesh. Since 1947, a third structure, Karachi standard Urdu, has advanced.

Definitions of Noun Phrase

The term 'Expression' is utilized to mean some of the time gatherings of words and in some cases a solitary word (Shuja 1999:16). An expression is a syntactic unit headed by a lexical class like thing, modifier, intensifier, action word or relational word. The syntactic unit headed by these classes is known as Noun Phrase, Adverb Phrase, Adjective Phrase, prepositional Phrase and Verb Phrase. The proposed present examination manages the Noun phrases in English and Urdu language.

George Yule(2020) in his book *The Study of Languages*, expresses that Noun Phrase (NP) contains thing in addition to different constituents. For instance: in English 'the young lady is a thing expression where 'young lady' is the head thing and 'the' will be the constituent (i.e., article). Paul R. Kroeger in his Analyzing Grammar expresses that a Noun Phrase is a phrasal constituent whose head is a thing or pronoun joined by a lot of modifiers. As per him, Noun Phrases in many dialects can work as subject, essential or auxiliary article and objects of relational words. Kroeger discusses different sorts of non-head constituents happening in a thing expression in the majority of the dialects of the world. The most significant constituents are determiners, supplements and aides (or modifiers).

Purpose of research

This research investigates the structural similarities and dissimilarities between English and Urdu noun phrase structure. To begin with, Urdu is linguistically a rich language with SOV word request. It further shows a similar action word understanding wonder which different dialects of the Indo Aryan locale display like Hindi, Urdu, Kashmiri, Gojri and Punjabi (for instance, Vale 1948, Kachru 1966, Bahl 1974, Hook 1974, Masica 1976, Hook 1991). The second significant component of this language is that it is article less language. As opposed to English, Urdu doesn't have the article framework because of which word request is utilized to show the definiteness while explicitness is planned through the case framework. The



ISSN Online: 2709-9180
ISSN Print: 2709-9172

**INTERNATIONAL BULLETIN
OF LITERATURE AND LINGUISTICS**

Vol. 6 No. 2 (June) 2023

Pages: 23-50

Published by: Research Syndicate

Email: researchsyndicate.vv@gmail.com Website: <http://www.researchsyndicate.com.pk>

fundamental reason for portraying these distinctions and similitude's will be gotten by computing the file of closeness, in term of structure, among Urdu and English.

Statement of problem

As in different dialects, Noun Phrase (اسمی ترکیب ,NP) in Urdu likewise extends from a solitary word to (hypothetically) an interminably long development involving different expressions as its constituents. NP may contain various word classes and expressions including pronouns, modifiers, things and quantifiers. It is imperative to discover the specific principles which administer how NP might be framed in Urdu. This isn't just imperative to comprehend the syntax of Urdu yet in addition fundamental for building up the computational models of the language. Case Phrase (KP1) in Urdu is shaped by basically NP or NP followed by Case Marker, cm). The issue is that Urdu speakers have the issue with the right decision of the English NP itself. How constituents as modifiers, relational word and articles shift in thing expressions of Urdu language as contrast with English language. There are syntactic and basic contrasts and similitudes according to the thing expression in the two dialects (English and Urdu) that we will dissect in this article.

Objectives

The points and destinations of research work are being referenced underneath:

- a. To watch and evaluate the utilization and capacity of Noun phrases in Urdu and English language.
- b. To contemplate the head component of NP in both the dialects.
- c. To research the constituents in the structure of NP in Urdu and English.
- d. To discover syntactic and basic similitudes and dissimilarities according to NP in both these two dialects.
- e. To enhance and create Urdu and English language, and furthermore to make this work valuable and available to other people.

Research questions

- 1- How to represent the fact that a complex NPs may behave both like a syntactically complex structure with respect to certain phenomena, and like a syntactically simple structure with respect to other phenomena?
- 2- What Urdu speakers have the problem with the correct choice of the English noun phrases itself?
- 3- How constituents in the structure of noun phrases in Urdu and English vary?



ISSN Online: 2709-9180
ISSN Print: 2709-9172

**INTERNATIONAL BULLETIN
OF LITERATURE AND LINGUISTICS**

Vol. 6 No. 2 (June) 2023

Pages: 23-50

Published by: Research Syndicate

Email: researchsyndicate.vv@gmail.com Website: <http://www.researchsyndicate.com.pk>

- 4- How the Urdu adjectives change with the genders of the noun they modify?
- 5- How the structures of sentences vary when a preposition in Urdu (which comes after nouns) and preposition in English (which comes before the noun) vary?

Assumptions

This paper reads NP development with the end goal of calculation sentence structure for Urdu. The NP can contain statements, different expressions, and rudimentary things as its constituent. A few constituents (expressions and conditions) of NP additionally have the capacity of accepting NP as their constituent (relative proviso, post-positional expression, and case state and so forth); while others generally show up at a subjecting position of NP (for example noun, pronoun, numeral, non-verbal descriptive word). This paper centers around the subjecting things just, in light of the fact that every one of different developments requires its different investigation and examination. Hence, genitive pronoun and verbal descriptors are likewise excluded from this paper.

Practical

Therefore, it is hoped that this comparative study will help in the linguistic and socio-cultural studies which would enable the reader to peep into other culture of the world and civilization. It is to be noted here that comparative study occupies a significant place in the field of linguistics. The purpose of such studies is to suggest similarities and dissimilarities between two languages under investigation. This article facilitates us to learn that how we can compare and contrast the grammar of the two languages by the Tree Diagrams.

Literature Review

Ortega (2011) says that SLA investigate revolves around four noteworthy zones of that how people get acquainted with the second language in the wake of having capacity in the principle language and how it isn't equivalent to their first language. By then, what are the components that development the vacillation all in all, how the second language understudies achieve the neighborhood like capacity at the moved periods of language learning. So as far as the case helpful classes in English language are concerned.

Definition of Noun Phrase

A thing expression is a gathering of related words that can go about as a solitary thing like solidarity inside a sentence. Prahi (2006:1) makes reference to, "A thing expression is a gathering of words that accomplishes crafted by a thing. A thing expression is either a pronoun or any gathering of words that can be supplanted by a pronoun."

The Formation of Noun Phrase



ISSN Online: 2709-9180
ISSN Print: 2709-9172

**INTERNATIONAL BULLETIN
 OF LITERATURE AND LINGUISTICS**

Vol. 6 No. 2 (June) 2023

Pages: 23-50

Published by: Research Syndicate

Email: researchsyndicate.vv@gmail.com Website: <http://www.researchsyndicate.com.pk>

According to Thewlis (2000:148), the formation of noun phrase consists of a determiner and noun plus all its modifiers. Here are the formations of noun phrase:

I. Determiners + noun

- a. **The** pencil; **these** pencils
- b. **My** pencil; **some** pencils

II. Determiner +modifiers +noun

- a. Some **really well used** notebook
- b. Some really well used **grammar** notebook with blue cover.

III. Determiner (+modifiers) + noun + (modifying clauses and phrases)

- a. Some really beautiful used grammar notebook **with blue cover**.

IV. Arrangement of Descriptive Adjectives

VALUATION/OPINION	APPEARANCE	AGE	COLOR	ORIGIN
Great Terrible Appalling Intriguing Pleasant Keen	Size/measure Huge Little Low High Overwhelming Shape Round Square Triangle Condition Chipped Broken Spoiled	Old Youthful New Collectible	Red Green Blue Stripped Splendid Green Dim blue Profound purple	Geological French Mexican Japanese Material Wooden Vegetable Cotton Bass

Within a category there are some possible variations

EXAMPLES	EXPLANATION
a. A large, round, glossy orange b. A large, glossy round orange c. A glossy, enormous round	Descriptive words of appearance generally follow the request in size, shape, condition. Be that as it may, different requests are also



ISSN Online: 2709-9180
ISSN Print: 2709-9172

**INTERNATIONAL BULLETIN
OF LITERATURE AND LINGUISTICS**

Vol. 6 No. 2 (June) 2023

Pages: 23-50

Published by: Research Syndicate

Email: researchsyndicate.vv@gmail.com Website: <http://www.researchsyndicate.com.pk>

orange	conceivable.
a. A Japanese silk fan b. A silk Japanese fan	Adjectives of source for the most part follow the request in geological material. In any case, other requests are conceivable.

V. Participle Modifiers

EXAMPLES	EXPLANATION
a. The fascinating lady recounted to the astonishing tale about experiences in Karachi. b. The intrigued lady listened cautiously to the astounding anecdote about the experience in Karachi.	a- Present participle changes specialists. The operators do the activity portrayed by participles. b- Past participle adjusts collectors. The recipients are influenced by the activity portrayed by the participle.

Carthy (2013) stated that NPs start with determiners which are put at the beginning of thing phrases. Sherman (2013) stated that the use of determiners with things explains that determiners tell if the reference is unequivocal or obscure. They demonstrate how much or what number of, whose, which one, and comparable data about thing that follows.

There are eight kinds of determiners:.

- 1- **Articles** (a,an,the)
 - The indefinite articles *a* or *an* signal the reference that is non specific or general.
 - The definite article *the* signals the reference that is specific.
- 2- **Possessive pronouns** (my, our, your, his, her, its, their).
- 3- **Relative pronouns** (whose, which, whichever, what, whatever)
- 4- **Demonstrative** (this, these, that, those).
 - Singular : *this* and *that*
 - Plural : *these* and *those*
- 5- **Indefinite pronouns** (any, each, few, other, some, etc.)
6. **Cardinal Numbers** (one, two, three, etc.)
7. **Ordinal Numbers** (last, first, second, etc)
8. **Possessive proper nouns** (Bob's, Sarah's America's)

Determiners in Urdu

Without a doubt, as show Kachru et al. (2008) in the IndoAryan and Dravidian vernaculars determiners are put before the head thing. Urdu, being a person from Indo-Aryan family, follows a comparable structure. For instance *voh-laṛkii* for instance that is youngster one. All the South Asian Languages, including Urdu, are etymologically indistinct in light of the fact



ISSN Online: 2709-9180
ISSN Print: 2709-9172

**INTERNATIONAL BULLETIN
OF LITERATURE AND LINGUISTICS**

Vol. 6 No. 2 (June) 2023

Pages: 23-50

Published by: Research Syndicate

Email: researchsyndicate.vv@gmail.com Website: <http://www.researchsyndicate.com.pk>

that they are all activity word last. Kachru (2008 p.77) point out that these 'customary syntactic features are open in for all intents and purposes all the lingos being spoken in Pakistan'. As analyzed previously, by far most of the South Asian tongues don't have determiners and without this system the ergative case marker – ne and accusative case marker – ko work as expressness markers. For instance:

. a. **Aslam-ne** **kitaab** **uthai**

Aslam picked a book.

b. **Aslam-ne** **kitaab-ko** **uthaya**

Aslam picked up the book.

This paper is astoundingly useful in understanding the structure of thing phrases for the present proposed study. The book entitled Noun Phrase Structure of English and Urdu (1999) by Shuja is an illustrative book in the examination of thing phrases in both English and Urdu tongues which began from a comparative language family-the Indo-European. This is a relative report that has been done to perceive resemblances and dissimilarities of the pieces of thing phrases between these two lingos. It generally focuses to find the features of the fundamental properties of the two lingos at the surface level. First, it endeavors to determine certain pieces of the structure of thing phrase in both these tongues uninhibitedly and a short time later ponders to show similarities and differentiations between them. Two sections are resolved to explain the thing phrases in English and Urdu: the principal structure, head part of thing phrases. It in like manner makes reference to the modifiers (enlightening words, determiners, and qualifier, verbal, etc.) of head N in NPs in both the tongues. The last region is stressed over the assessment of the English and Urdu thing phrase tantamount to Head and modifier positions.

Treebank

There are two significant sorts of syntactic explanation: state structure and reliance structure.

The expression structure examination of sentence was presented by Chomsky. The primary major Treebank, Penn Treebank has express organized explanation [Marcus]. The Penn Treebank was motivation for some tree banks for different dialects. Penn Treebank (PTB) has around 25 expression names. Figure 1 (a) shows an expression structure of an English sentence commented on utilizing PTB rules. Han presented 9 all inclusive expression names to be specific Noun Phrase (NP), Verb Phrase (VP), Adjectival Phrase (AJP), Adverbial Phrase (AVP), Prepositional Phrase (PP), Sentence (S), Conjunction Phrase (CONJP), Coordinated Phrase (COP) and others (X). The other kind of syntactic comment is reliance structure. It's essential spotlight in not on the word request or electorate, yet it manages the syntactic relations between the words. The most significant achievement is the presentations of general conditions [Marie Catherine]. There are in excess of 100 tree banks clarified utilizing widespread conditions [J. Nivre]. For Urdu, there was no openly accessible Treebank toward the beginning of this venture. There were prior deals with computational language structure of Urdu. Urdu Program actualizes significant pieces of Urdu language utilizing Lexical Functional Grammar (LFG) system [M. Butt]. A significant syntactic structure bank is Urdu Treebank [R. Bhatt] that has Urdu corpus



commented on utilizing Panini style conditions A parser was likewise evolved utilizing this Treebank of 1400 sentences.

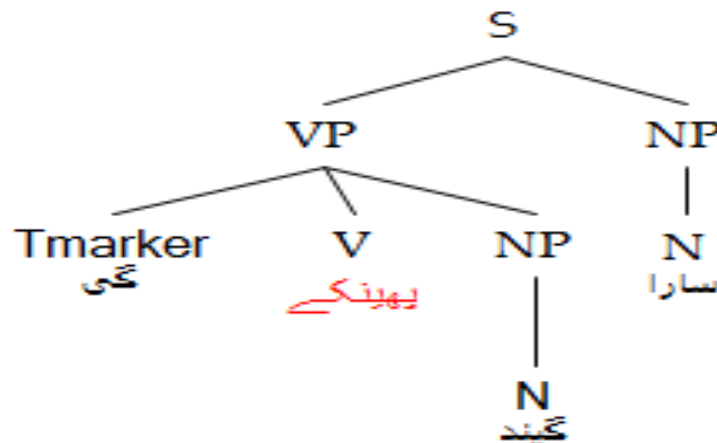
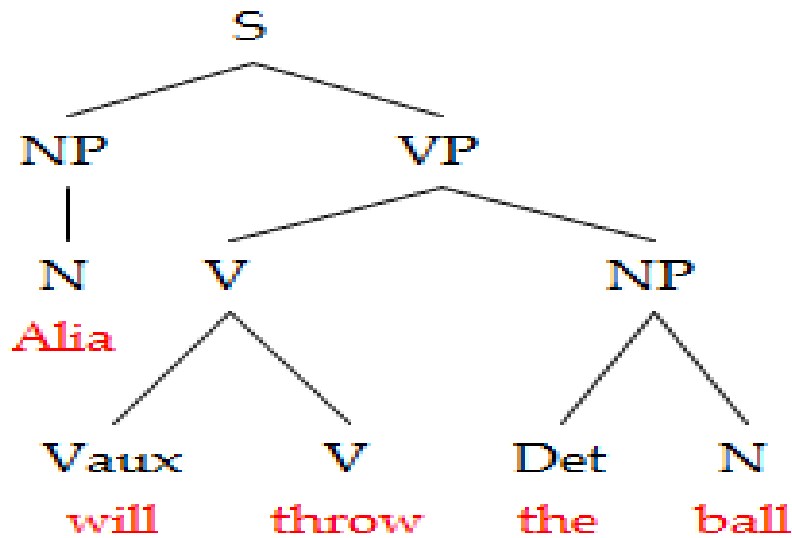

This area is about certain ideas and essential structure square of dialects especially Urdu language. The contribution of lumping task is grammatical form labels more often than not. Significant bit of this area presents the peruse about grammatical feature labels.

Research Gaps

Applying contemporary generative hypothesis, the analysts pioneer another pattern, subsequently; contemporary X-bar configuration and NP structures not at all like the conventional point of view would uphold the Urdu NP structures. For example, in contrast to the conventional view, it would concentrate on state as the fundamental constituent. The NP clarification would undeniably be as per the idea that constituents are organized as progressing



ISSN Online: 2709-9180
ISSN Print: 2709-9172

**INTERNATIONAL BULLETIN
OF LITERATURE AND LINGUISTICS**

Vol. 6 No. 2 (June) 2023

Pages: 23-50

Published by: Research Syndicate

Email: researchsyndicate.vv@gmail.com Website: <http://www.researchsyndicate.com.pk>

arrangement of lexical things. Developments in constituents, nonetheless, would furnish more prominent bits of knowledge into the quirks concerning the Urdu language. Until this point in time, the developments in constituents if there should be an occurrence of Urdu have so a been talked about or investigated by a couple of scientists in line with the constituent's examination as done in English.

Research Methodology

This research is mixed method approach. Information arrangement is a critical task in organizing the current assessment one thing phrases. For this, we got to libraries, web, books, etc. For social occasion data, we have visited Libraries, Universities, Library of the Department of Foreign Languages, etc. The sole made records out of the two vernaculars contain distinctive unique books, journals, articles, course books, monographs, word references and sentence structure, etc. For Urdu data, we generally oversaw Syed Abdul Malik's Pora Gawot Pohila Bohag (novel, written in 1930). It is to be referenced that a bit of the data for thing phrases in Urdu language has been alluded to from my instinctual data too as I am the neighborhood speaker of this language. Presentation of Data Examples given from the sources tongues are presented by using their own orthography. Examination Methods Used To accomplish this work, generally Historical procedure, Comparative technique and Descriptive system have been followed. True strategy is used to mull over the establishment information on Urdu and English language like history, root and headway. Since the current work is a close relation between two tongues, comparable strategy is significant in this interesting circumstance. It helps in contrasting the semantic structure of both the vernaculars relating to thing phrase improvement. Spellbinding method is helpful to delineate the general structure of thing phrases in Urdu and English. For this, first we accumulated data and examination is done on these data. In the wake of separating the data, we portrayed the likeness and dissimilarities found in both these two vernaculars. It is to be referenced here that since the current assessment is centered around sentence structures i.e., the thing phrases, the various revelations at the phonetic or phonological level have not been presented here. A mixed framework is used to separate the syntactic assortments in English and Urdu Language.

Tag used	Tag Description
ADJP	Adjectival Phrase
ADVP	Adverbial Phrase
CONJP	Conjunction phrase



ISSN Online: 2709-9180
ISSN Print: 2709-9172

**INTERNATIONAL BULLETIN
OF LITERATURE AND LINGUISTICS**

Vol. 6 No. 2 (June) 2023

Pages: 23-50

Published by: Research Syndicate

Email: researchsyndicate.vv@gmail.com Website: <http://www.researchsyndicate.com.pk>

FRAG	Fragment
INTJP	Interjection Phrase
NP	Noun Phrase
PRN	Parenthetical Phrase
QP	Quantifier Phrases
S	Sentence
SBAR	Subordinate Conjunction
SBARQ	Question subordinate Conjunction
SQ	Yes/No question phrase
VP	Verb Phrase
WHADJP	WH Adjectival
WHADV	WH Adverbial Phrase
WHNP	WH Noun Phrase
X	Unknown

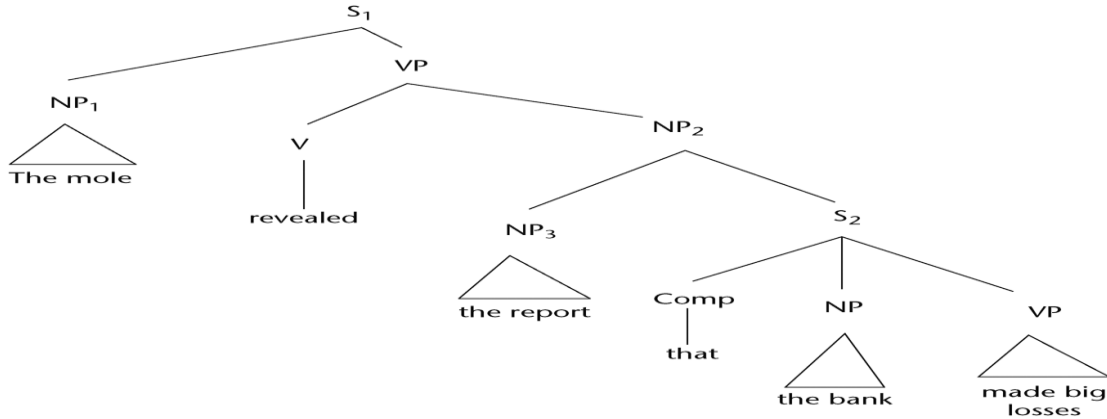

Cyclic Principle (a)

Frame work

The Tree Diagrams are used as the framework of this research. These Tree structures give a precise procedure to get the syntactic similarities and differences in both the linguistic systems with the help of setting a comparison of their structures (through their flat structures).

Population

The information is gathered from various sources like books and individual perceptions. The subjective methodology was embraced for the current examination. Since the current examination is a similar work between two dialects: English and Urdu, the information has been gathered from both these two dialects. For these reasons, the composed types of the two dialects are the sole wellspring of information assortment. We didn't go for the expressed information that go under the essential information assortment as we thought that it was hard to associate with local speaker of English language here, so much of the time. Furthermore, simultaneously it was by all accounts over the top expensive to go to remote for information gathering. Thusly, choice has been taken to delimit our examination work inside the NPs information as it were.

Data collection

The information is gathered from primary sources like books and individual perceptions. The subjective methodology was received for the current investigation. Since the current examination is a relative work between two dialects: English and Urdu, the information has been gathered from both these two dialects.

Data Analysis

Common Nouns



ISSN Online: 2709-9180
ISSN Print: 2709-9172

INTERNATIONAL BULLETIN
OF LITERATURE AND LINGUISTICS

Vol. 6 No. 2 (June) 2023

Pages: 23-50

Published by: Research Syndicate

Email: researchsyndicate.vv@gmail.com Website: <http://www.researchsyndicate.com.pk>

A thing, for example, a book or canine, that can be gone before by the clear article and that speaks to one or the entirety of the individuals from a class is called Common Nouns. English and Urdu language the two has regular things for instance:

NP
|
N
Girl

NP
|
N
لڑکی

Proper Nouns

Formal people, places or things are explicit names of unique individuals, spots, things, or a title. Formal people, places or things consistently have a capital. Both English and Urdu have Proper Nouns for instance:

NP
|
N
London

NP
|
N
لندن

Countable Nouns

Tally things are regular things that can take a plural, can join with numerals or quantifiers (e.g., one, two, a few, each, most), and can take an uncertain article (an or an). Instances of tally things are seat, nose, and event. Following are a few instances of Countable Nouns in English and Urdu both:

NP
/ \
Q/D N
Three books

NP
/ \
N Q/D
کتابیں تین

Mass Nouns

Mass things (or non-check things) vary from include things in definitely that regard: they can't take plural or join with number words or quantifiers. A number can't be utilized to evaluate a mass thing. Mistaken: four woods, one rice, three valor's. English and Urdu both utilize the mass things in comparative manner without making it plural and consolidating with quantifiers.

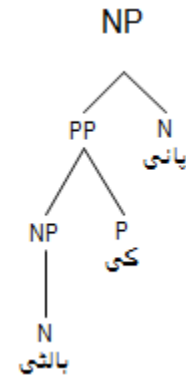
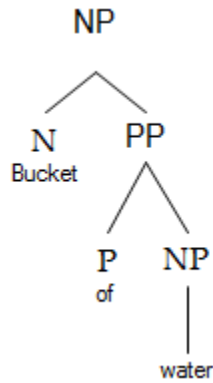

Collective Nouns

Aggregate things are things that allude to bunches comprising of more than one individual or substance, in any event, when they are arched for the solitary. Models incorporate board of trustees, group, and school (of fish).

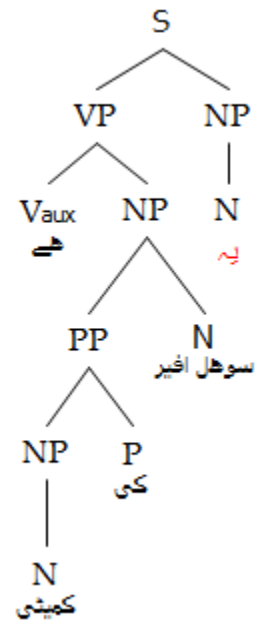
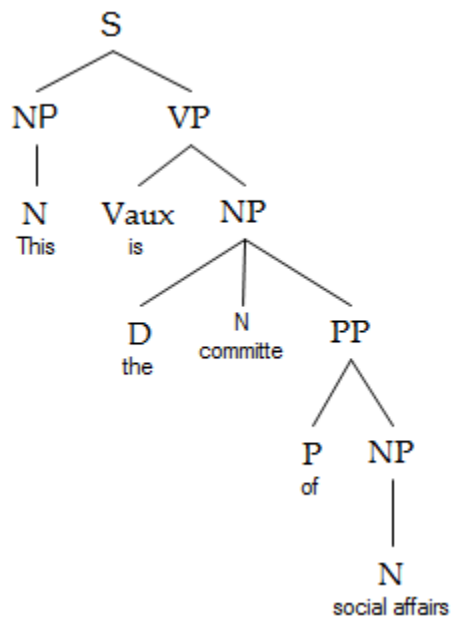

Concrete Nouns

A solid thing is the name of a person or thing that we experience through our faculties, sight, hearing, smell, contact or taste. Solid things can be normal, legitimate, countable, uncountable, aggregate, and show up in solitary or plural structures. The following are a few instances of solid things discovered both in English and Urdu:



ISSN Online: 2709-9180
ISSN Print: 2709-9172

INTERNATIONAL BULLETIN
OF LITERATURE AND LINGUISTICS

Vol. 6 No. 2 (June) 2023

Pages: 23-50

Published by: Research Syndicate

Email: researchsyndicate.vv@gmail.com Website: <http://www.researchsyndicate.com.pk>

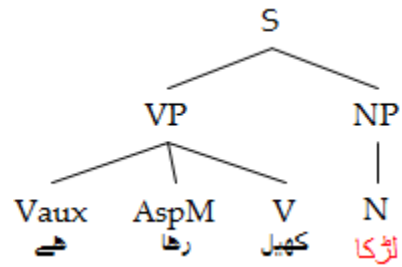
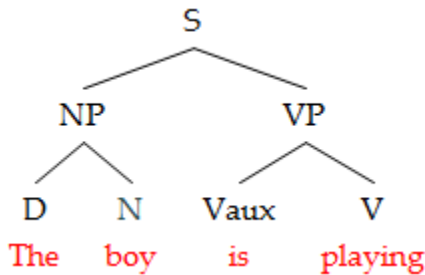

Abstract Nouns:

Unique things are something contrary to solid things. These are things that name things you can't see, smell, taste, hear, or contact. They allude to feelings, thoughts, ideas, principles, convictions, or your condition. Following are a portion of the instances of Abstract things comparable in English and Urdu both:

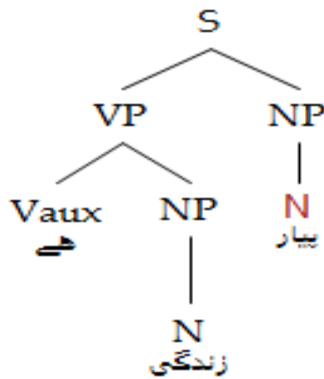
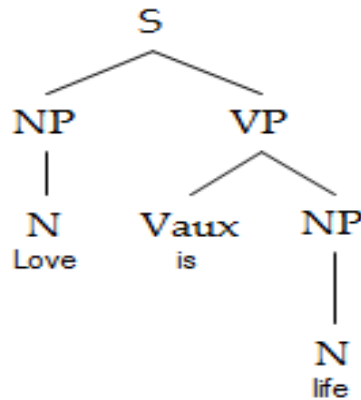

In contrast to Urdu, English things don't have sex, albeit numerous things allude explicitly to male or female people or creatures, similar to mother, father, bull, tigress. Syntactic



ISSN Online: 2709-9180
ISSN Print: 2709-9172

**INTERNATIONAL BULLETIN
OF LITERATURE AND LINGUISTICS**

Vol. 6 No. 2 (June) 2023

Pages: 23-50

Published by: Research Syndicate

Email: researchsyndicate.vv@gmail.com Website: <http://www.researchsyndicate.com.pk>

sex was a completely profitable inflectional class in Old English, Modern English has a substantially less unavoidable sexual orientation framework, principally dependent on characteristic sex.

There are a couple of hints of sex stamping in Modern English:

- Some loanwords curve as indicated by sexual orientation, for example, entertainer/on-screen character, or fair/blonde.
- The third individual particular pronouns (and their possessive structures) are sexual orientation explicit: "he/his" (manly sex, by and large utilized for guys), "she/her(s)" (ladylike sex, for females), "it/its" (fix sex, fundamentally for articles and reflections), "one/one's" (regular sex, for any person or thing).

Pronouns

In semantics and language, a pronoun is a word or structures those substitutes for a thing or thing phrase. It is a specific instance of a master structure. Pronouns have customarily been viewed as one of the grammatical forms, albeit numerous advanced scholars would not see them as a solitary particular word class, on account of the assortment of capacities performed by words which are classed as pronouns. Regular sorts incorporate the individual pronouns, relative pronouns, inquisitive pronouns, expressive pronouns and inconclusive pronouns.

There is no differentiation between the manly and ladylike sexual orientations in Urdu pronouns. A similar pronoun is utilized for both 'he' and 'she' (the action word state frequently gives the data, be that as it may). There is then again a qualification among proximate and inaccessible as an outsider looking in: Urdu recognizes a 'he/she/it' which is close within reach and a 'he/she/it' which is a ways off. Urdu pronouns may allude to particular or plural individuals or things. Plural pronouns alluding to individuals may 3Like things, pronouns may happen in the nominative case (for instance as subjects of sentences) or in the angled case (trailed by postpositions).

Demonstrative Pronouns

In English, expressive pronouns will be pronouns that point to explicit things. "This, that, these, those are Demonstrative Pronouns that substitute things when the things they supplant can be comprehended from the specific circumstance. They likewise show whether they are supplanting solitary or plural words. A few sentence structures portray them as individuals from the class of capacity words called "determiners", since they recognize things and different nominal.



ISSN Online: 2709-9180
ISSN Print: 2709-9172

INTERNATIONAL BULLETIN
OF LITERATURE AND LINGUISTICS

Vol. 6 No. 2 (June) 2023

Pages: 23-50

Published by: Research Syndicate

Email: researchsyndicate.vv@gmail.com Website: <http://www.researchsyndicate.com.pk>

- "This" (singular) and "These" (plural) refer to an object or person NEAR the speaker.
- "That" (singular) and "Those" (plural) refer to an object or person further AWAY.

Correspondingly in Urdu expressive pronoun "ye", 'this' alludes to a person or thing close within reach. The decisive pronoun "vo", 'that' alludes to a person or thing further away. The decisive pronoun 'ye' and 'vo' are indistinguishable in structure to the individual pronouns 'ye' and 'vo' (signifying 'he', 'she', 'it'). In the nominative case, the plural types of 'ye' and 'vo' are indistinguishable from their particular structures. Just the action word shows whether the pronoun alludes to a particular or plural thing.

Num	English	Urdu
		<u>Roman Transliteration</u>
1	What is this?	ye kya hai?
2	This is a water pot.	Ye gharaa hai.
3	What are those?	wo kya hain?
4	These are water pots.	Ye gharain hain.

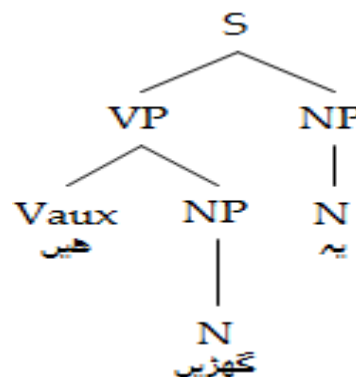
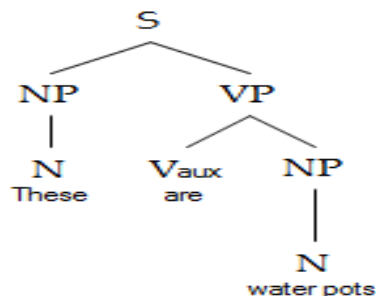

The demonstrative pronouns also function as adjectives in both English and Urdu.

Num	English	Urdu
		<u>Roman Transliteration</u>
1	This water pot is big.	Ye ghara bara hai.
2	That well is very deep.	Vo kuan buhat gahra hai.
3	The water is cold.	pani thanda hai.

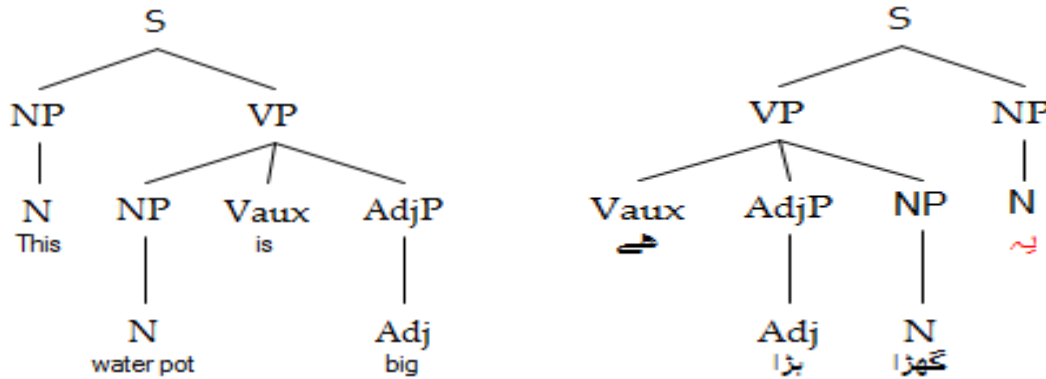

Personal Pronouns

In Linguistics a pronoun having a positive individual or thing as a forerunner and working syntactically similarly as the thing that it replaces. In English, the individual pronouns incorporate as I, you, he, she, it, we, and they, and are arched for case. In English individual pronouns have distinctive subject and item structure. This can be found in the table underneath:

Possessive Pronouns

A possessive pronoun is a grammatical form that credits proprietorship to a person or thing. Like some other pronoun, it substitutes a thing expression and can forestall its redundancy. For instance, the expressions in English "These glasses are mine, not yours", the words "mine" and "yours" are possessive pronouns and mean "my glasses" and "your glasses," individually. In Urdu the possessive types of pronouns are linguistically descriptive words and concur with the things they qualify.

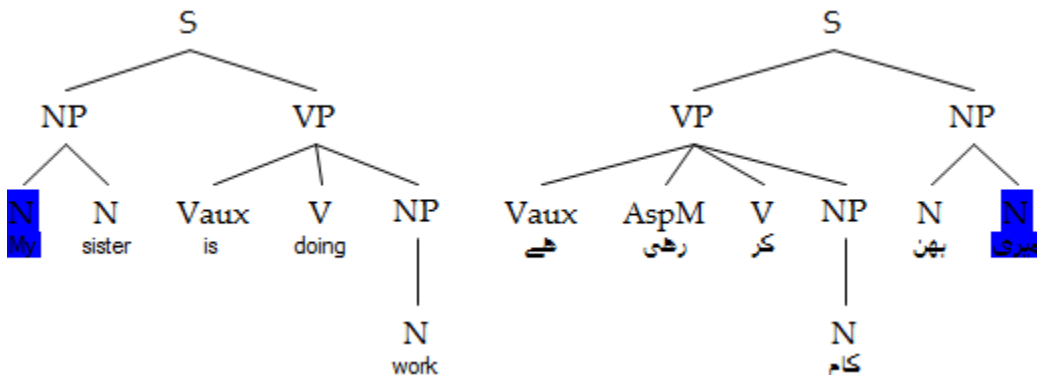

Reflexive Pronoun



ISSN Online: 2709-9180
ISSN Print: 2709-9172

INTERNATIONAL BULLETIN
OF LITERATURE AND LINGUISTICS

Vol. 6 No. 2 (June) 2023

Pages: 23-50

Published by: Research Syndicate

Email: researchsyndicate.vv@gmail.com Website: <http://www.researchsyndicate.com.pk>

Reflexive pronouns will be pronouns that allude back to the subject of the sentence or provision. In English, the capacity of a reflexive pronoun is among the implications of the words myself, yourself, themselves (age-old), himself, herself, itself, oneself, ourselves, yourselves, and themselves. In the announcements "I see him" and "She sees you", the articles are not indistinguishable people from the subjects, and standard pronouns are utilized. In any case, when the individual being seen is equivalent to the individual who is seeing, the reflexive pronoun is utilized: "I see myself" or "She sees herself". The possessive descriptor apna 'one's own' is fill in for the possessive types of individual pronouns when the subject of the sentence has the article. 'apna' concurs with the thing it qualifies.

Num	English	Urdu
		<u>Roman Transliteration</u>
1	Ahmad is looking at his (own) watch.	Ahmad apni ghari deakh raha hai
2	Sara is washing her (own) clothes.	Sara apnay kapray dho rahi hai
3	Ahsan is working on his (own) computer.	Ahsan apnay computer pe kaam kar raha hai.

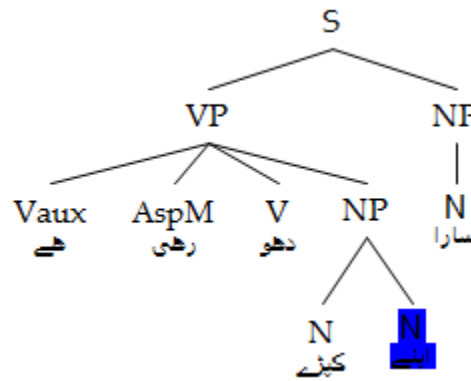
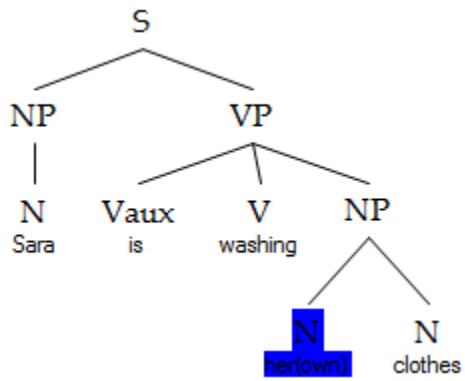

Indefinite Pronouns

Inconclusive pronouns will be pronouns that are not unmistakable in importance. At the end of the day they are not explicit in which thing they supplant. They might be solitary or plural, and must match the action word in number. Someone, somebody, something, anyone, anybody, anything, no one, nobody, nothing, everyone, everybody and everything are a portion of the normal inconclusive pronouns utilized in English. In Urdu 'koi' is utilized both as a pronoun and a descriptive word. As a pronoun, it signifies 'somebody', 'anybody'. On the off chance that the sentence is negative, it signifies 'nobody'. Thus 'kuch', 'something', 'anything' is utilized both as a pronoun and a descriptive word. As a pronoun, it signifies 'something'. On the off chance that there is a negative word in the sentence, it amounts to 'nothing', 'not anything'. 'kuch' doesn't have a slanted structure.



ISSN Online: 2709-9180
ISSN Print: 2709-9172

INTERNATIONAL BULLETIN
OF LITERATURE AND LINGUISTICS

Vol. 6 No. 2 (June) 2023

Pages: 23-50

Published by: Research Syndicate

Email: researchsyndicate.vv@gmail.com Website: <http://www.researchsyndicate.com.pk>

Num	English	Urdu
		<u>Roman Transliteration</u>
1	There is someone at the door.	Darvazay par koi hai.
2	No one is at home	Ghar par koi nahin.
3	Do something.	Kuch karo

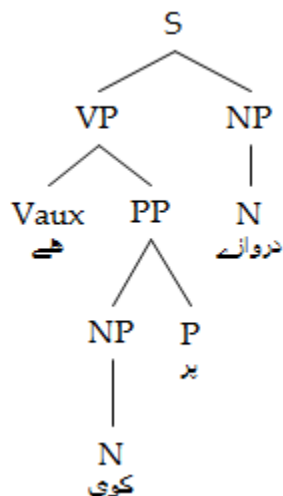
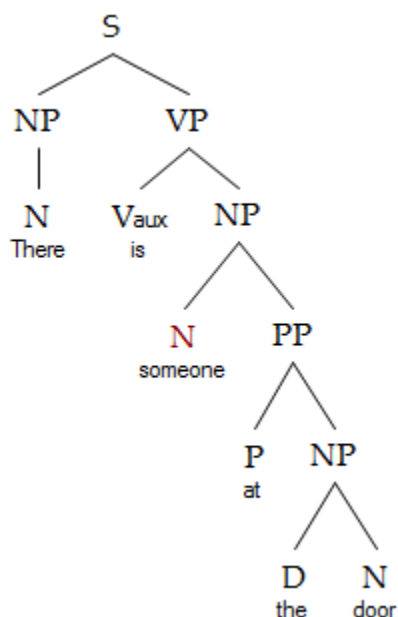

Relative Pronouns

A relative pronoun is a pronoun used to stamp a relative statement, and having a similar referent as the component of the fundamental proviso (normally a thing or thing phrase) which the relative condition adjusts. The most widely recognized relative pronouns in English are who/whom, whoever/whomever, whose, that, and which. In Urdu the relative pronoun comparing to 'vo' and 'ye' is 'jo' جو to 'who' and 'which'.

Num	English	Urdu
		<u>اردو</u> <u>Roman Transliteration</u>
1	The room that Alia built is small.	Jo kamra Alia nay banaya hai vo choota hai
2	This is the house which Ali built.	Ye vo ghar hai jo Ali nay banaya hai.
3	This is Sana who worked with me.	Ye Sana hai jo meray sath kaam thin.

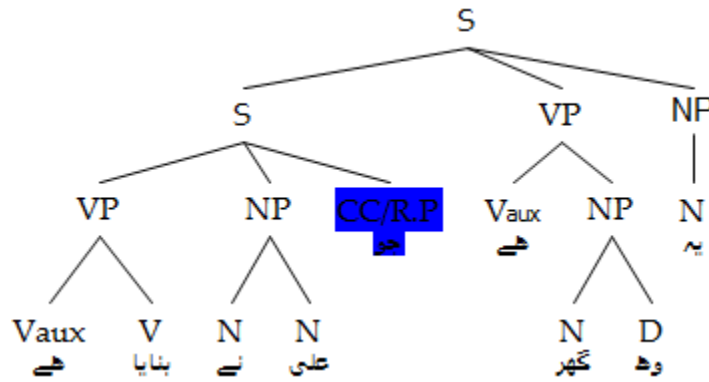
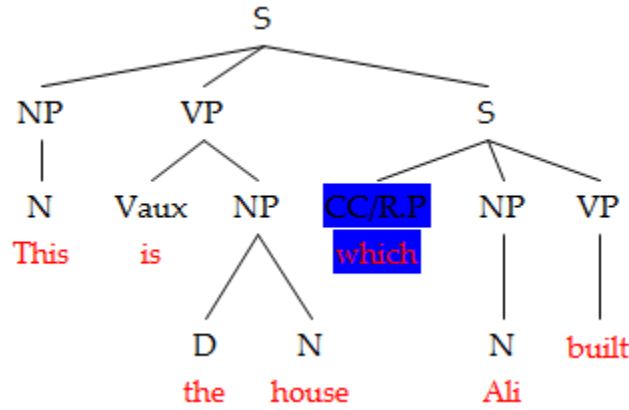

Phrases

1. Noun Phrase
2. Verb Phrase
3. Adjective Phrase
4. Adverbial
5. Genitive Phrase
6. Prepositional Phrase

Noun Phrase

In English, a thing expression is worked around a solitary thing, for instance: A jar of roses remained on the table. While, Noun Phrase (اسمی ترکیب, NP) in Urdu additionally runs from a solitary word to (hypothetically) an unendingly long development including different expressions as its constituents. At the point when things are to be utilized in sentences as a component of discourse, at that point there are a few etymological subtleties which should be thought of. For instance, different words can change a thing and things have attributes, for example, sexual orientation, number, and so forth. At the point when all such required subtleties



ISSN Online: 2709-9180
ISSN Print: 2709-9172

INTERNATIONAL BULLETIN
OF LITERATURE AND LINGUISTICS

Vol. 6 No. 2 (June) 2023

Pages: 23-50

Published by: Research Syndicate

Email: researchsyndicate.vv@gmail.com Website: <http://www.researchsyndicate.com.pk>

are gathered with the thing, the subsequent structure is known as thing phrase (NP). The essential structure of Urdu thing phrase is "(M) H (M)", where (M) is a modifier and (H) is the top of a NP. Head is the word which is necessary and modifiers can or can't be there. In Urdu modifiers are of two kinds that are pre-modifiers and post-modifiers.

Pre-modifiers are those which preceded the head before the head for example (موٹا چوہا) (mota choha "fat rodent"), and post-modifiers are those that come after the head for example (تم سب "all of you" (تم سب)).

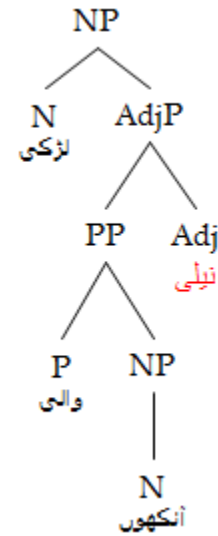
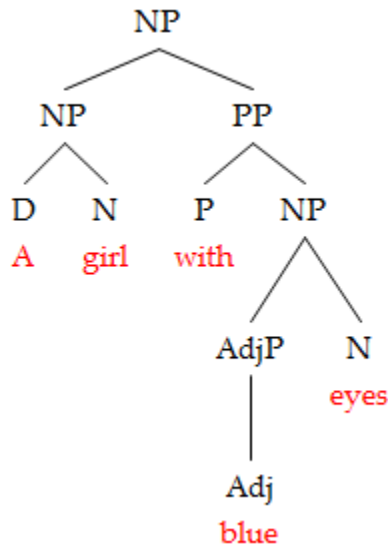

Verb Phrase

An action word express is a solitary or a gathering of words that go about as a predicate. Action word expressions can likewise contain at least one helper action words before the primary action word. Helper action words, for example, be, have, might are helping action words and help the principle action word to make up action word phrases. Essentially in Urdu, we discover action word phrases.

An assortment of action word phrases exist in Urdu including straightforward action word phrases, conjunct action word expressions and compound action word phrases. The Urdu VP is an intricate structure that has various parts: the principle part is action word and afterward there are different assistants appended to action word. At the end of the day Urdu action word express contains an action word followed by at least one assistants (AUX) and action word tense markers (VBT). Each is spoken to by a different word.



ISSN Online: 2709-9180
ISSN Print: 2709-9172

INTERNATIONAL BULLETIN
OF LITERATURE AND LINGUISTICS

Vol. 6 No. 2 (June) 2023

Pages: 23-50

Published by: Research Syndicate

Email: researchsyndicate.vv@gmail.com Website: <http://www.researchsyndicate.com.pk>

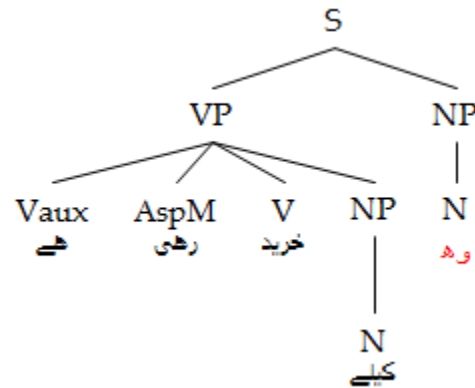
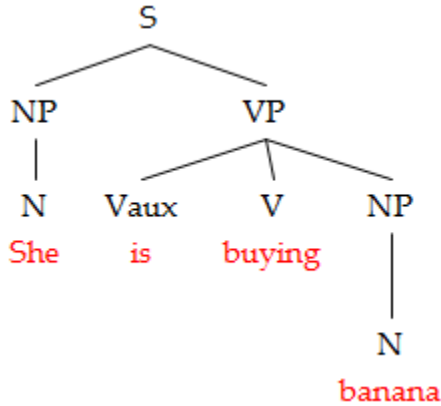

Adjectival Phrase

A word or a gathering of words that accomplishes crafted by a modifier is called a descriptor expression. It by and large adjusts or depicts a thing or pronoun and gives an extra insight regarding the importance of a thing. Descriptive word phrases are generally framed from an intensifier that is discretionary, trailed by the head (H) that is regularly a modifier.

Num	English	Urdu	<u>Roman Transliteration</u>
1	Sana is <i>innocent child</i> .	Sana masoom si bacchi hai.	Sana masoom si bacchi hai.
2	Ahmad is <i>talented</i> .	Ahmad bara zaheen hai.	Ahmad bara zaheen hai.
3	A girl <i>from Canada</i> .	Aik larki Canada say.	Aik larki Canada say.



ISSN Online: 2709-9180
ISSN Print: 2709-9172

INTERNATIONAL BULLETIN
OF LITERATURE AND LINGUISTICS

Vol. 6 No. 2 (June) 2023

Pages: 23-50

Published by: Research Syndicate

Email: researchsyndicate.vv@gmail.com Website: <http://www.researchsyndicate.com.pk>

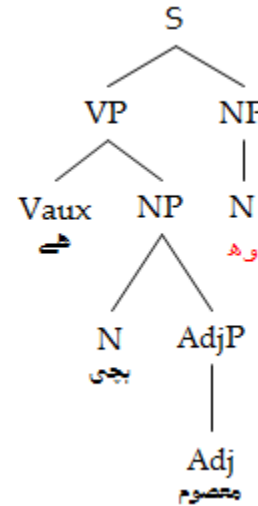
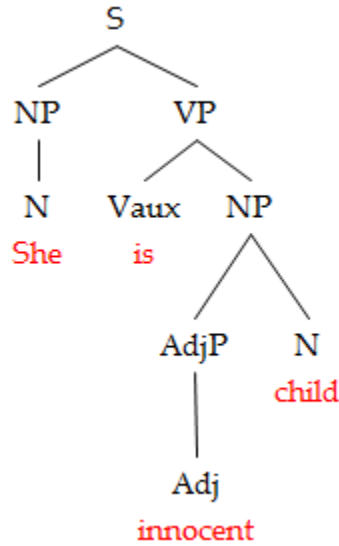

Adverbial Phrases

Num	English	Urdu	<u>Roman Transliteration</u>
1	She was <i>walking slowly</i> .		Bilal ahista ahista chal raha tha.
2	She cried <i>loudly</i> .		Vo zoor say chilai.
3	Sana works <i>carefully</i> .		Sana dehaan saykam krti hai.

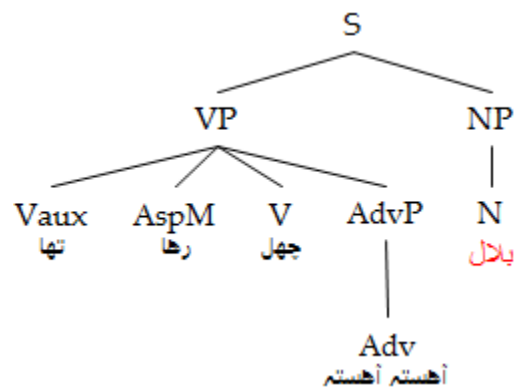
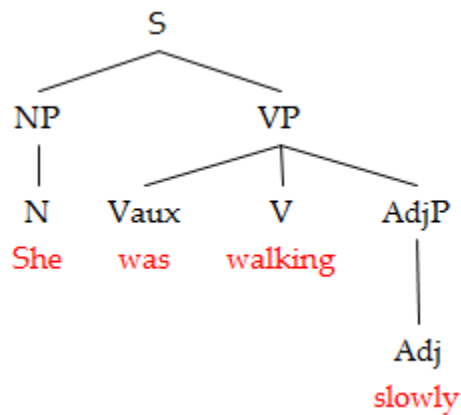



PREPOSITIONAL/POSTPOSITIONAL PHRASE

Num	English	Urdu	Roman Transliteration
1	By the grace of God		Khuda kay fazal say
2	The girl looked at the door		Larki nay darwazay ko dekha
3	There are six rooms in a building.		Building ma chee kamry han.

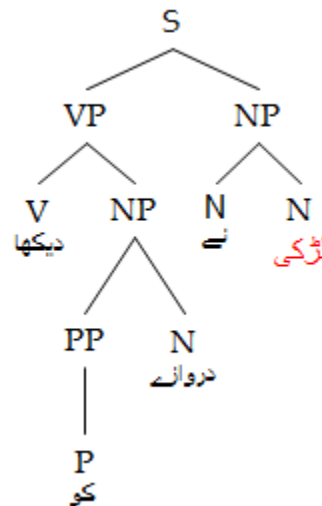
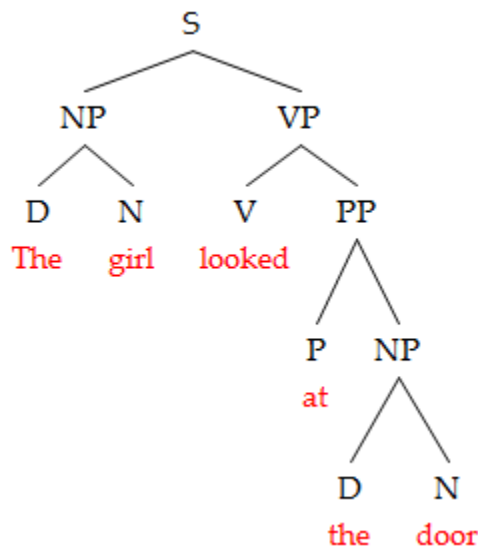

Sentence

Up until this point, we have been taking a gander at parts of sentences, for example, the thing or thing phrase and the action word and action word state, they have their own interior structure. The thing or a thing expression and the action word or an action word expression can be supposed the English

any rate the action word.

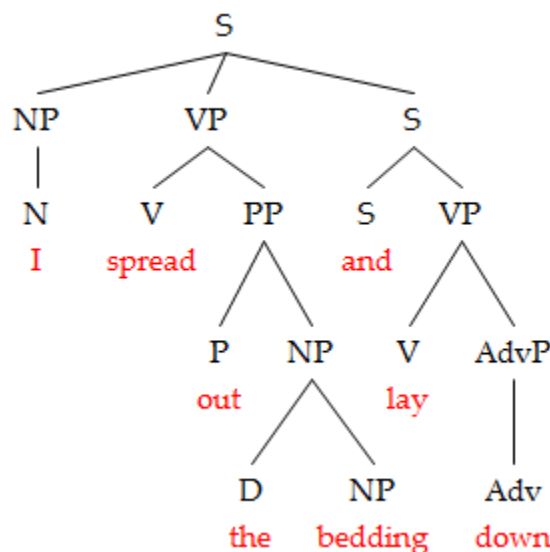

to be the essential 'building hinder' of sentence. Indeed, even the most straightforward sentence will have at thing working as a subject and an



ISSN Online: 2709-9180
ISSN Print: 2709-9172

INTERNATIONAL BULLETIN
OF LITERATURE AND LINGUISTICS

Vol. 6 No. 2 (June) 2023

Pages: 23-50

Published by: Research Syndicate

Email: researchsyndicate.vv@gmail.com Website: <http://www.researchsyndicate.com.pk>

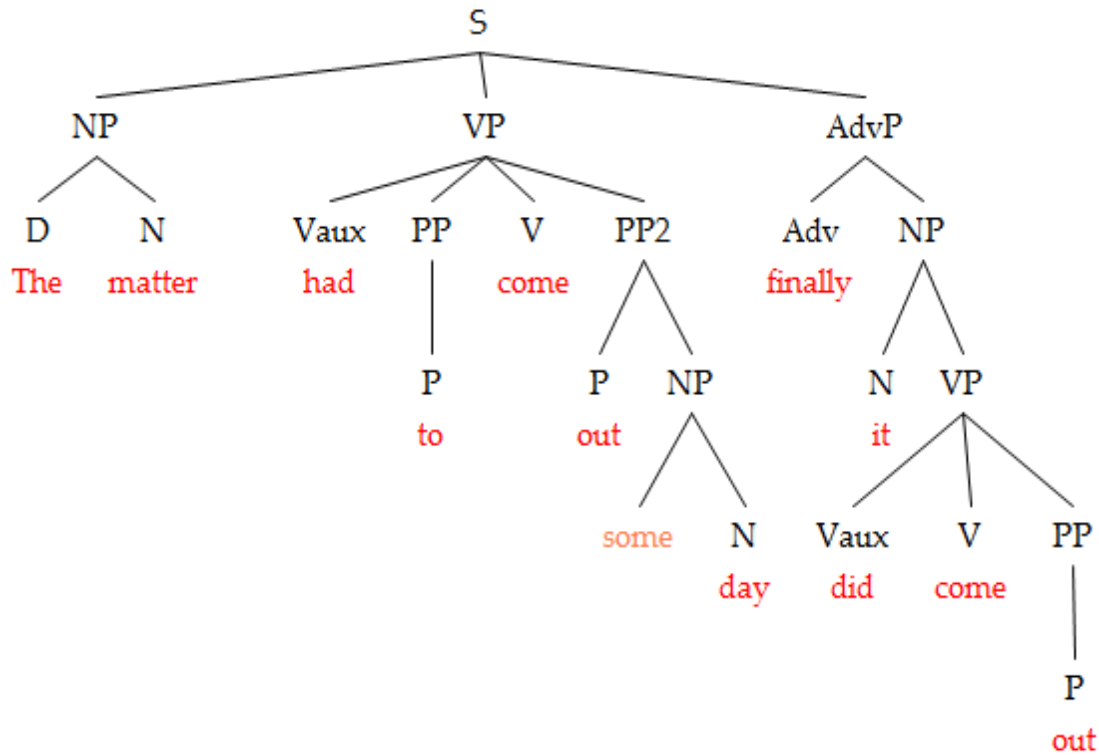
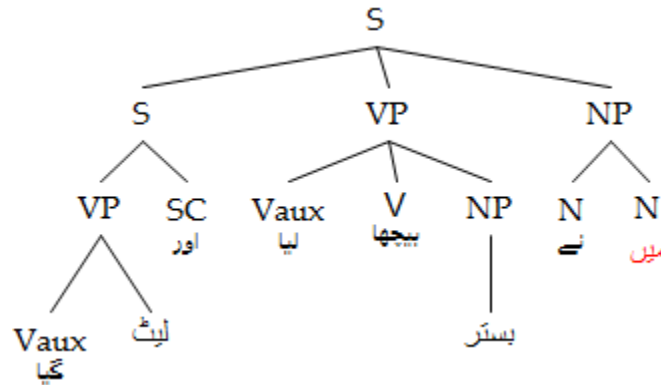



ISSN Online: 2709-9180
ISSN Print: 2709-9172

INTERNATIONAL BULLETIN
OF LITERATURE AND LINGUISTICS

Vol. 6 No. 2 (June) 2023

Pages: 23-50

Published by: Research Syndicate

Email: researchsyndicate.vv@gmail.com Website: <http://www.researchsyndicate.com.pk>

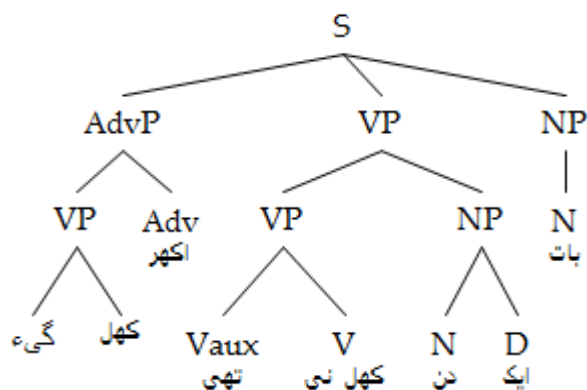

Findings and Discussion

Urdu and English, the two most basic dialects spoken in Pakistan have its own unmistakable sentence structure and its principles. On the word Level we can see that both Urdu and English offer similar significant classes. Both have things, pronouns, descriptive words, action words, verb modifiers yet the significant differentiation lies in syntactic sex. English things don't have sexual orientation though in Urdu all things are either manly or ladylike. Likewise Urdu descriptive words change with the sexual orientations of thing they adjust and are assembled as checked and plain. It is imperative to take note of that, there are no unequivocal articles in Urdu though English language has and every normal thing can be gone before by 'an', 'an' or 'the'. It is additionally fascinating to take note of that Urdu utilizes post-positions (which come after things) as opposed to English relational word (which precedes things). Albeit both English and Urdu have formal people, places or things, however dissimilar to English its absolutely impossible to recognize normal and formal people, places or things with first letter capitalized. Likewise Urdu and English both have countable things which can take plural shape or can be adjusted by numerals, quantifiers however dissimilar to English, Urdu can't take inconclusive articles to alter particular things. Different things anyway are utilized in a comparable manner in both English and Urdu.

On account of pronoun anyway the significant contrast lies in sexual orientation. In Urdu pronouns there is no differentiation among manly and female sexual orientations and a similar pronoun is utilized for both 'he' and 'she' however the qualification lies among proximate and removed in third individual. Both English and Urdu pronouns have diverse subject and article structure yet if there should arise an occurrence of Urdu they are called nominative and angled. Possessive pronouns in Urdu are syntactically descriptive word and concur with things they qualify. Both English and Urdu have attributive and predicative descriptors, yet Urdu utilizes post-positions to make modifiers dissimilar to English. Likewise the similar level of Urdu is very straightforward than English.



ISSN Online: 2709-9180
ISSN Print: 2709-9172

**INTERNATIONAL BULLETIN
OF LITERATURE AND LINGUISTICS**

Vol. 6 No. 2 (June) 2023

Pages: 23-50

Published by: Research Syndicate

Email: researchsyndicate.vv@gmail.com Website: <http://www.researchsyndicate.com.pk>

Intensifiers are comparable in both English and Urdu. An action word anyway is the most significant component in English and an action word would itself be able to pass on the total importance. Be that as it may, in Urdu it must be conjugated for tense, number and sexual orientation. Urdu has tenses that comparative those utilized in English: present straightforward, past nonstop, and so on., yet there is an absence of correspondence in their utilization to communicate different implications. This prompts the normal abuse by Urdu students of the present persistent when in English the current straightforward is required. Likewise like English, Urdu has transitive action words (which require an immediate article) and intransitive action words (which don't take objects), however the distinction plays a substantially more noteworthy job in Urdu.

In contrast to English, Urdu is an Indo-Aryan language, and is a free expression request language, for example the expressions inside a sentence have free request and in any case, the words inside an expression have a fixed request. As the request for the phrases is variable, the case markers (CM), which are unequivocally written in Urdu as isolated words, help to decide the job of each expression in the sentence. In Urdu not at all like English a thing expression isn't really worked around a solitary noun however, it tends to be involved different expressions also. Additionally in Urdu dialects an assortment of action, word phrases are available including conjunct and compound action word expressions and it contains an action word followed by at least one helper (AUX) and action word tense markers (VBT). The significant distinction lies in English and Urdu on express level is the normal utilization of Genitive expression in Urdu which is not, at this point utilized in Modern English. Likewise Urdu has a post-positional expression rather than English prepositional expression, which contrasts in the way that it goes before objects.

Conclusion

In English, similar to the expression, a proviso is additionally a gathering of words, however, it is not the same as an expression. In a proviso, you should locate a subject and predicate. So also, in Urdu, a provision is a piece of sentence having a subject and predicate however not a total sentence all alone. English and Urdu both have comparative sorts of statements anyway the decisions of subjecting combination is constrained in Urdu instead of English. On the sentence level, there is a significant distinction in the structure of English and Urdu. The essential structure in English sentence is S-V-O (Subject-Verb-Object) and In Urdu the fundamental structure of a sentence is S-O-V (Subject-Object-Verb). In different words the action word in Urdu by and large comes rearward in the sentence yet in English it precedes the item. Likewise Urdu commonly utilizes a subjunctive that considerate solicitations, which have the word request of articulations as opposed to questions.

References



ISSN Online: 2709-9180
ISSN Print: 2709-9172

**INTERNATIONAL BULLETIN
OF LITERATURE AND LINGUISTICS**

Vol. 6 No. 2 (June) 2023

Pages: 23-50

Published by: Research Syndicate

Email: researchsyndicate.vv@gmail.com Website: <http://www.researchsyndicate.com.pk>

- Adger, D. (2003). *Core syntax: A minimalist approach* (Vol. 33): Oxford University Press Oxford.
- Braj B. Kachru, Y. K. (2008). *Language in South Asia*. UK: Cambridge.
- Buckley, J. (1997). *Hindi and Urdu Dictionary Phrase Book*. London: Rough Guides Ltd.
- Chen Huang-hua and Chen Hsin-His , *Extracting Noun Phrases from Large-Scale Texts: A Hybrid Approach and Its Automatic Evaluation*. in Proceedings of the 32nd annual meeting on Association for Computational Linguistics Las Cruces, New Mexico Pages: 234 – 41, 1994.
- Croft William, *Typology and universals*, 2nd edition. Cambridge: Cambridge University Press, 2003.
- Delacy, R. (1998). *HINDI & URDU PHRASEBOOK. 2nd edition*. Australia: Lonely Planet Copyright.
- Garland Chomsky, N. 1970. Remarks on Nominalization. In Readings in English Transformational Grammar, R.A. Jacobs and P.S. Rosenbaum, eds. Ginn and Co., Waltham, Mass.
- Green T., *The necessity of syntax markers: two experiments with artificial language*, Journal of Yule, G. (2020). *The study of language*. Cambridge university press. Yule, G. (2020). *The study of language*. Cambridge university press. Verbal Learning and Behaviour 18:481-496, 1979.
- Haq, M. Abdul. “١٩٨٤“، نحو و صرف اردو. Anjuman-e-Taraqqi Urdu (Hind).
- Kachru, Y., & Nelson, C. L. (2006). *World Englishes in Asian Contexts: Globalization, Science Fiction, and the Cybernetic Revolution*: Hong Kong University Press.
- M. P. Marcus, B. Santorini, and M. A. Marcinkiewicz, “Building a large annotated corpus of English: the Penn Treebank”, *Computational Linguistics*, 19(2), 1993.
- M. Butt, et. al., “The Parallel Grammar project”, In Proceedings of COLING 2002. Workshop on Grammar Engineering and Evaluation, 2002.
- Partee B. H., and Borschev, V. 2003. Genitives, relational nouns, and argument-modifier Ambiguity. In *Modifying Adjuncts*, eds. E. Lang, C. Maienborn and C. Fabricius-Hansen, 67-112.
- Schmidt, R. L. (1999). *Urdu: An Essential Grammar: An Essential Grammar*. London: Routledge.
- Yule, G. (2020). *The study of language*. Cambridge university press.